

**FIRST**® **LEGO**® *League*

**TUT**  **RIALS**

teach

share

learn

# PASSIVE ATTACHMENTS

SESHAN BROTHERS

# WHAT IS AN ATTACHMENT?

- A mechanism you build that can assist your robot in accomplishing a task (e.g. pick up an object, drop off an object)
- This mechanism is “attached” to the base robot
- For a competition robot, the goal is to design attachments that work consistently every time and are easy to add/remove



# PASSIVE VS. POWERED

- Passive attachments do not require any external power. They typically work based on the movement of the robot or simple uses of gravity.
  - This lesson covers some simple types of passive attachments
- Powered attachments need some type of power source. This includes power from motors, pneumatics and other sources.

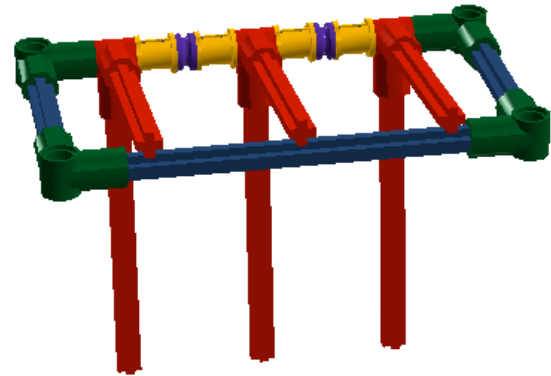



# ONE-WAY GATE OR CURTAIN

- Passive attachment that lets objects in but not out
- Uses gravity
- Can be modified to any size



2 x  1/2 BUSH - Medium Lilac

4 x  BUSH FOR CROSS AXLE - Flame Yellowish Orange

2 x  CROSS AXLE 5M - Earth Blue

3 x  CROSS AXLE 6M - Bright Red

3 x  CROSS AXLE 8M - Bright Red

1 x  CROSS AXLE 10M - Black

1 x  CROSS AXLE 10M - Earth Blue

3 x  ANGLE ELEMENT, 90 DEGREES [6] - Bright Red

4 x  ANGLE ELEMENT, 90 DEGREES [6] - Earth Green

# TRY BUILDING ONE...

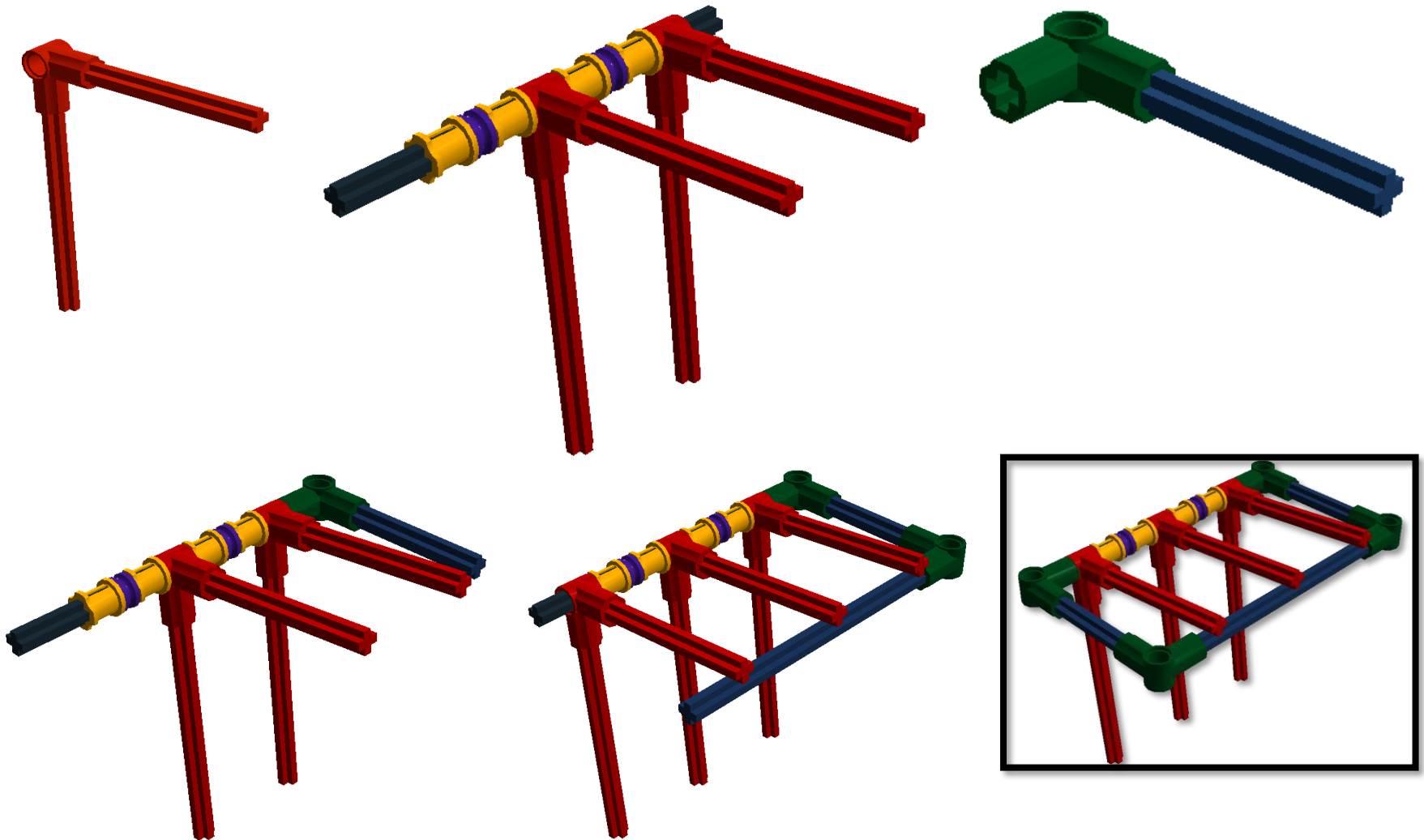



# CARABINER

- Passive attachment that lets objects in but not out
- Can be made using gravity or using rubber bands
- Can be modified to any size





1 x  TECHNIC 15M BEAM - Bright Reddish Violet

4 x  TECHNIC ANG. BEAM 3X5 90 DEG. - Bright Blue

2 x  TECHNIC ANG. BEAM 3X5 90 DEG. - Bright Green

2 x  TECHNIC ANGULAR BEAM 3X7 - Bright Red

4 x  1/2 BUSH - Bright Yellow

1 x  CROSS AXLE 3M - Flame Yellowish Orange

4 x  BUSH FOR CROSS AXLE - Medium Stone Grey

2 x  CROSS AXLE 4M - Black

8 x  CONNECTOR PEG W. FRICTION 3M - Flame Yellowish Orange

1 x  3M CONNECTOR PEG - Flame Yellowish Orange

# TRY BUILDING ONE...

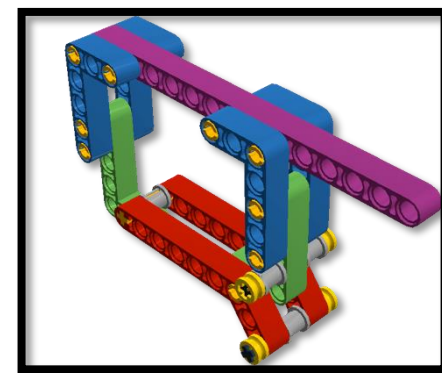
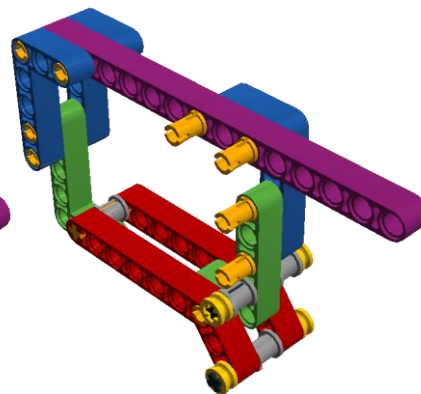
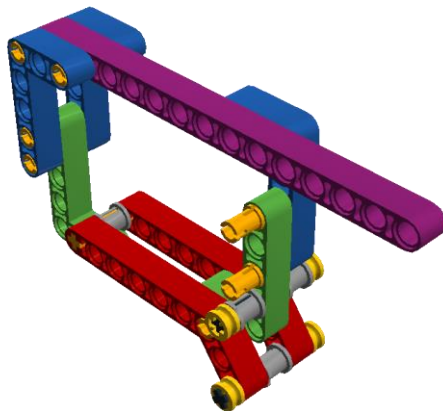
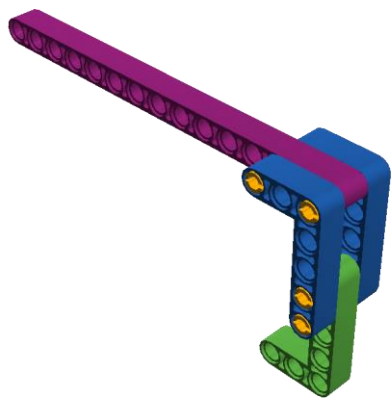
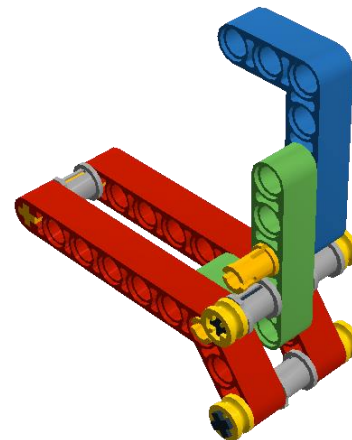
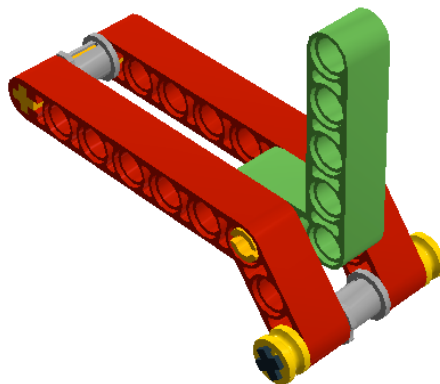
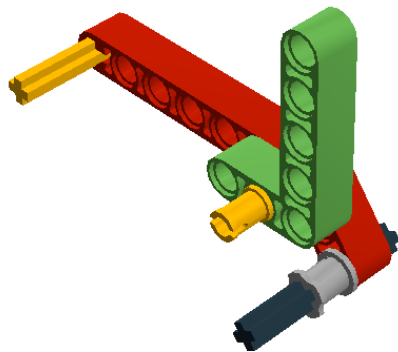

Add rubber bands on bushings as needed

# CREDITS

- This tutorial was created by Sanjay Seshan and Arvind Seshan
- More lessons at [www.ev3lessons.com](http://www.ev3lessons.com) and [www.flltutorials.com](http://www.flltutorials.com)



This work is licensed under a [Creative Commons Attribution-NonCommercial-ShareAlike 4.0 International License](https://creativecommons.org/licenses/by-nc-sa/4.0/).